

SLEWING WALL CRANE (WD)

Comprising:

- 2) Jib
- 3) Trolley
- 4) Traction limit
- 5) Cover with buffer
- 6) Electric supplies
- 7) Console

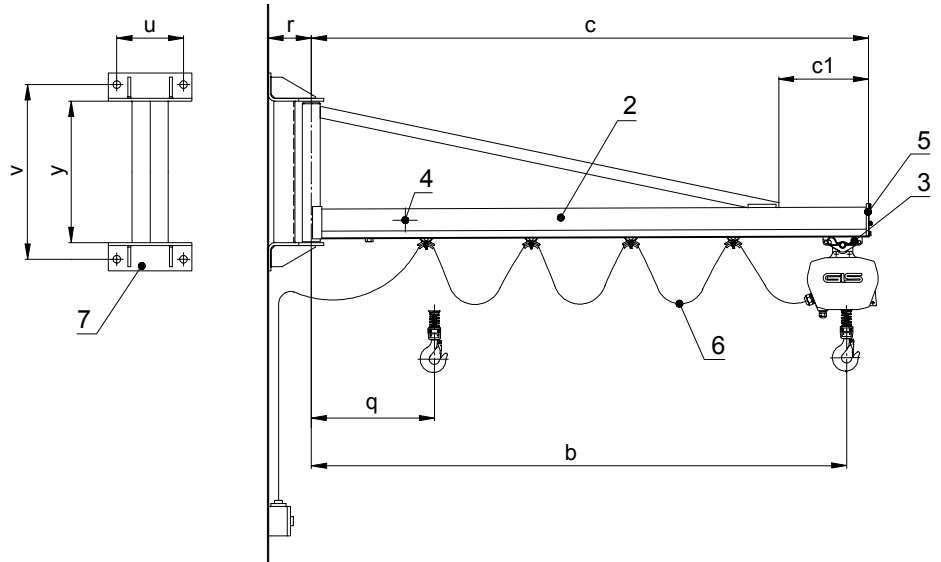

The deflection of the jib tip at maximum load is between $c/250$ and $c/800$ (c = length of jib).

The electric supplies consisting of one mains operation switch (surface mounting type), one cable gland PG 21 for flat cable and one extension PG 16/21 (mains operation switch), one cable gland PG 21 for flat cable (GIS electric chain hoist), cable trolleys and flat cable $4 \times 1.5 \text{ mm}^2$ (according to the length of the jib b). The length of the flat cable is calculated by the maximum assembled height of 4 m measured from lower flange of jib.

WD number	1	2	3	4	5	6	7	8	9	10	11	12	13	14	15	16	17	18	19
Capacity [kg]	160	160	160	320	320	320	320	500	630	630	500	800	800	800	800	1000	1000	1000	1000
b [mm]	1890	2890	3890	1890	2890	3880	4880	1770	2880	3880	4880	1880	2880	3880	4880	1760	2760	3760	4760
c [mm]	2000	3000	4000	2000	3000	4000	5000	2000	3000	4000	5000	2000	3000	4000	5000	2000	3000	4000	5000
c1 [mm]	320	430	550	320	430	520	520	320	410	520	660	300	410	520	660	300	410	520	660
q [mm]	405	505	605	405	505	615	615	525	515	615	615	415	515	615	615	535	635	735	735
r [mm]	160	160	160	160	160	185	185	160	185	185	185	185	185	185	185	185	185	185	185
u [mm]	240	240	240	240	240	340	340	240	340	340	340	340	340	340	340	340	340	340	340
v [mm]	620	620	620	620	620	1020	1020	620	1020	1020	1020	1020	1020	1020	1020	1020	1020	1020	1020
y [mm]	501	501	501	501	501	901	901	501	901	901	901	901	901	901	901	901	901	901	901
GIS profile	KB I	KB I	KB I	KB I	KB I	KB II	KB II	KB I	KB II	KB II	KB II	KB II	KB II	KB II	KB II	KB II	KB II	KB II	KB II
Ordering ref.	9311.1019/160	9311.1020/160	9311.1021/160	9311.1022/320	9311.1023/320	9311.1024/320	9311.1025/320	9311.1026/500	9311.1027/630	9311.1028/630	9311.1029/500	9311.1030/800	9311.1031/800	9311.1032/800	9311.1033/800	9311.1034/1000	9311.1035/1000	9311.1036/1000	9311.1037/1000

Drilling plan and pressure on the fixing face

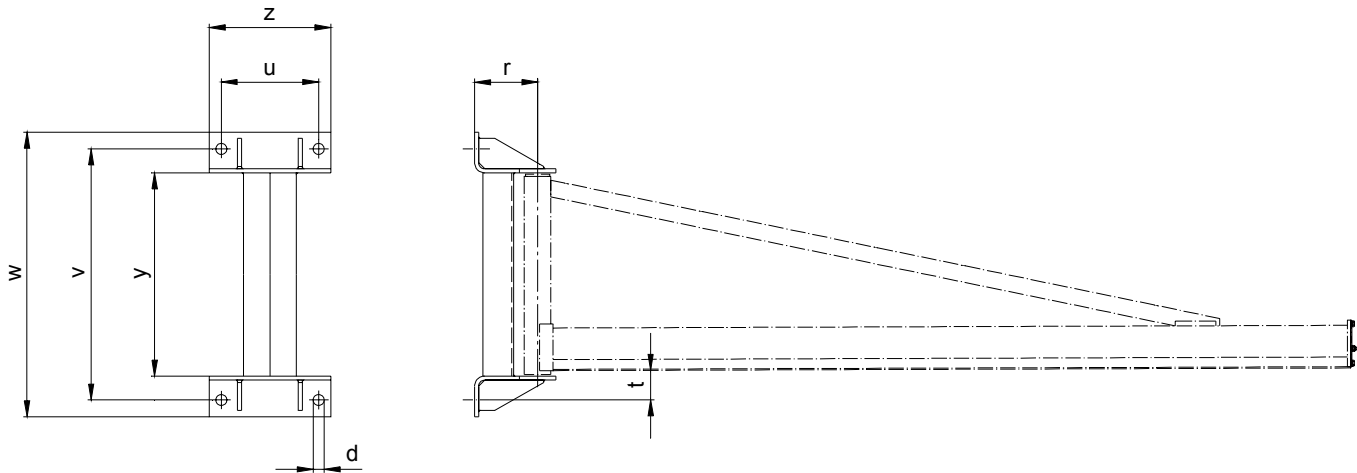

WD number	1	2	3	4	5	6	7	8	9	10	11	12	13	14	15	16	17	18	19
Console	1	1	1	1	1	2	2	1	2	2	2	2	2	2	2	2	2	2	2
d (hole \emptyset) [mm]	27	27	27	27	27	30	30	27	30	30	30	30	30	30	30	30	30	30	30
r [mm]	160	160	160	160	160	185	185	160	185	185	185	185	185	185	185	185	185	185	185
t [mm]	73	73	73	73	73	74	74	73	74	74	74	74	74	74	74	74	74	74	74
u [mm]	240	240	240	240	240	340	340	240	340	340	340	340	340	340	340	340	340	340	340
v [mm]	620	620	620	620	620	1020	1020	620	1020	1020	1020	1020	1020	1020	1020	1020	1020	1020	1020
w [mm]	700	700	700	700	700	1100	1100	700	1100	1100	1100	1100	1100	1100	1100	1100	1100	1100	1100
y [mm]	501	501	501	501	501	901	901	501	901	901	901	901	901	901	901	901	901	901	901
z [mm]	300	300	300	300	300	400	400	300	400	400	400	400	400	400	400	400	400	400	400
Anchor bolt	M24	M24	M24	M24	M24	M27	M27	M24	M27	M27	M27	M27	M27	M27	M27	M27	M27	M27	M27
Tensile force of each bolt [kN]	4.0	5.5	7.0	7.0	10.0	8.0	10.0	13.0	12.0	16.0	19.0	12.0	17.0	22.0*	27.0*	15.0	22.0*	29.0*	36.0*
Pressure between console and wall [N/mm ²]	0.35	0.45	0.6	0.6	0.85	0.5	0.65	1.0	0.75	1.0	1.2	0.75	1.1	1.4	1.7	0.95	1.4	1.8	2.2

* additional support to prevent distortion of the console is necessary (this to be arranged by the customer)

The fastening of the slewing wall crane is made by means of counter bearings, foundation bolts or safety straddling dowels. This material has to be supplied by the customer. When safety straddling dowels are used, these must be suitable for two and a half times the anchoring power.

GIS AG
 Hebe- und Fördertechnik
 Luzernerstrasse 50
 CH-6247 Schötz
 Telefon +41 (0)41 980 00 71
 Telefax +41 (0)41 980 16 06

tel@gis-ag.ch
 www.gis-ag.ch

GIS GmbH
 Hebe- und Fördertechnik
 Hohe-Flum-Strasse 44
 D-79650 Schopfheim
 Telefon +49 (0)7622 6773-0
 Telefax +49 (0)7622 6773-19

mail@gis-gmbh.de
 www.gis-gmbh.de