

Under Running Motorised Endtrucks

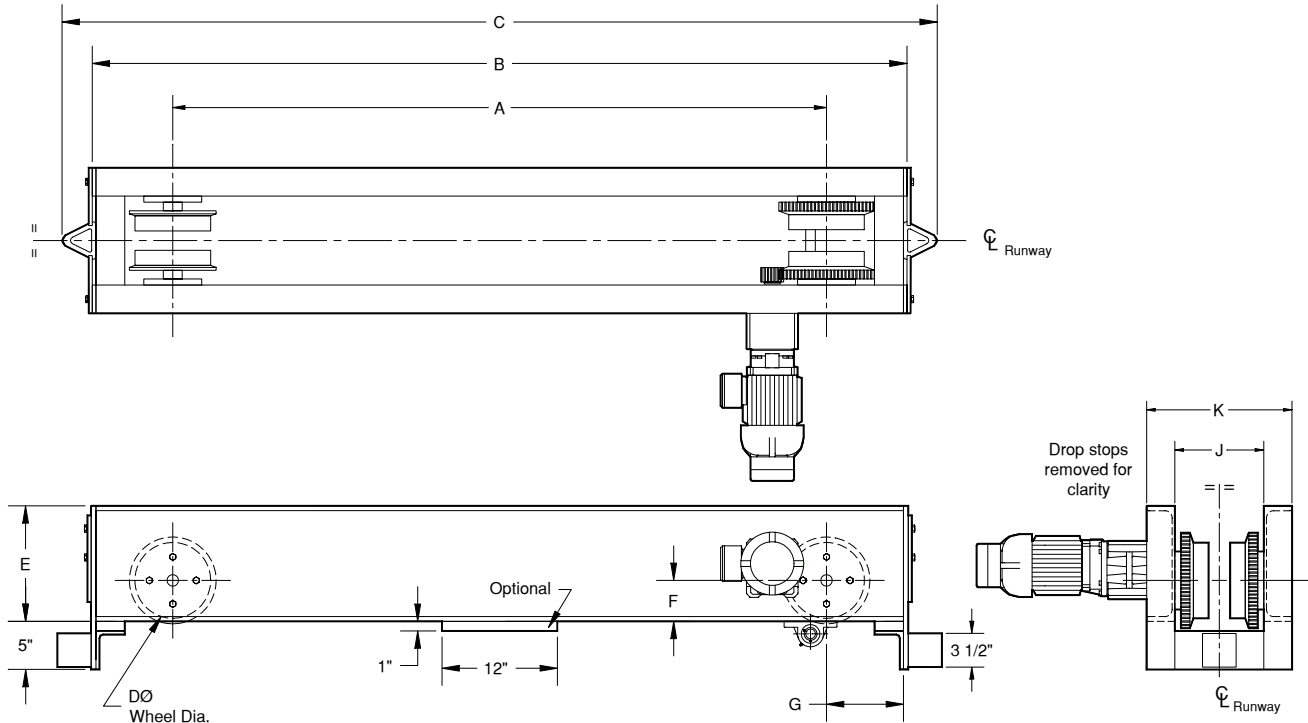

Capacity	Span	A	B	C	D	E	F	G	J	K	Weight (lbs)
2 Tons	< 40'	5'-0"	6'-0"	6'-8"	5 ¹ / ₈	8	3	6	Width of runway flange plus 3 ¹ / ₄	J + 4 ¹ / ₂	500
	40' - 50'	7'-0"	8'-0"	8'-8"	5 ¹ / ₈	8	3	6		J + 4 ¹ / ₂	570
	50' - 60'	10'-0"	11'-0"	11'-8"	5 ¹ / ₈	8	3	6		J + 4 ¹ / ₂	697
3 Tons	< 40'	5'-0"	6'-0"	6'-8"	5 ¹ / ₈	8	3	6	Width of runway flange plus 3 ¹ / ₄	J + 4 ¹ / ₂	553
	40' - 50'	7'-0"	8'-0"	8'-8"	5 ¹ / ₈	10	3	6		J + 5 ¹ / ₄	798
	50' - 60'	10'-0"	11'-0"	11'-8"	7 ⁷ / ₈	10	4 ¹ / ₄	6		J + 5 ¹ / ₄	930
5 Tons	< 40'	5'-0"	6'-0"	6'-8"	5 ¹ / ₈	10	3	6	Width of runway flange plus 3 ¹ / ₄	J + 5 ¹ / ₄	641
	40' - 50'	7'-0"	8'-0"	8'-8"	7 ⁷ / ₈	10	4 ¹ / ₄	6		J + 5 ¹ / ₄	849
	50' - 60'	10'-0"	11'-0"	11'-8"	7 ⁷ / ₈	12	4 ¹ / ₄	6		J + 5 ⁷ / ₈	1428
7¹/₂ Tons	< 40'	5'-0"	6'-0"	6'-8"	7 ⁷ / ₈	10	4 ¹ / ₄	6	Width of runway flange plus 3 ¹ / ₄	J + 5 ¹ / ₄	905
	40' - 50'	7'-0"	8'-0"	8'-8"	7 ⁷ / ₈	12	4 ¹ / ₄	6		J + 5 ⁷ / ₈	1306
	50' - 60'	10'-0"	11'-0"	11'-8"	12 ⁷ / ₁₆	15	7 ¹ / ₂	9		J + 6 ³ / ₄	2732
10 Tons	< 40'	5'-0"	6'-0"	6'-8"	7 ⁷ / ₈	12	4 ¹ / ₄	6	Width of runway flange plus 3 ¹ / ₄	J + 5 ⁷ / ₈	993
	40' - 50'	7'-0"	8'-0"	8'-8"	7 ⁷ / ₈	12	4 ¹ / ₄	6		J + 5 ⁷ / ₈	1336
	50' - 60'	10'-0"	11'-0"	11'-8"	12 ⁷ / ₁₆	15	7 ¹ / ₂	9		J + 6 ³ / ₄	2930

For special applications please consult the factory
 Hand geared, push-pull and patented track
 endtrucks upon request