

## Double Flange Wheels

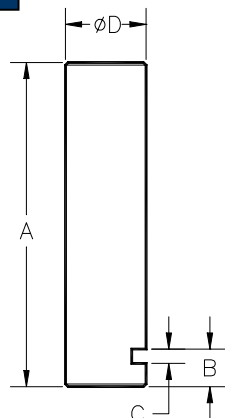

Model		A	B	C	D (Tread Dia.)	F	G (Pitch Dia.)	H	J (Axle Dia.)	K	N	W	No of Teeth	Gear Module	No of Brgs.	Max Wheel Load
DF120	mm	76	147	62	120	92	156	38	30	11	162	54	52	3	2	1836 kg
	in	2.99	5.79	2.44	4.72	3.62	6.14	1.50	1.18	0.43	6.38	2.13	52	3	2	4048 lbs
DF120B	mm	76	147	62	120	92	156	38	30	11	162	54	52	3	3	2932 kg
	in	2.99	5.79	2.44	4.72	3.62	6.14	1.50	1.18	0.43	6.38	2.13	52	3	3	6465 lbs
DF200	mm	84	229	85	200	103	247	42	45	14	252	57	82	3	2	3280 kg
	in	3.31	9.02	3.35	7.87	4.06	9.72	1.65	1.77	0.55	9.92	2.24	82	3	2	7232 lbs
DF200B	mm	84	229	85	200	103	247	42	45	14	252	57	82	3	3	5767 kg
	in	3.31	9.02	3.35	7.87	4.06	9.72	1.65	1.77	0.55	9.92	2.24	82	3	3	12716 lbs
DF320	mm	103	346	120	320	135	387	52	55	17	393	70	129	3	2	6850 kg
	in	4.06	13.62	4.72	12.60	5.31	15.24	2.05	2.17	0.67	15.47	2.76	129	3	2	15104 lbs
DF320B	mm	103	346	120	320	135	387	52	55	17	393	70	129	3	3	10420 kg
	in	4.06	13.62	4.72	12.60	5.31	15.24	2.05	2.17	0.67	15.47	2.76	129	3	3	22976 lbs
DF500	mm	130	550	150	500	170	552	65	70	18	560	90	138	4	3	14822 kg
	in	5.12	21.65	5.91	19.69	6.69	21.73	2.56	2.76	0.71	22.05	3.54	138	4	3	32683 lbs

## Axles for Double Flange Wheels



Model		A	B	C	D (Axle Dia.)
DFA30	mm	152	14	8	30
	in	5.98	0.55	0.31	1.18
DFA45	mm	181	14	8	45
	in	7.13	0.55	0.31	1.77
DFA55	mm	232	14	8	55
	in	9.13	0.55	0.31	2.17
DFA70	mm	292	17	10	70
	in	11.50	0.67	0.39	2.76

# Crane Wheels

## Single Flange Wheels

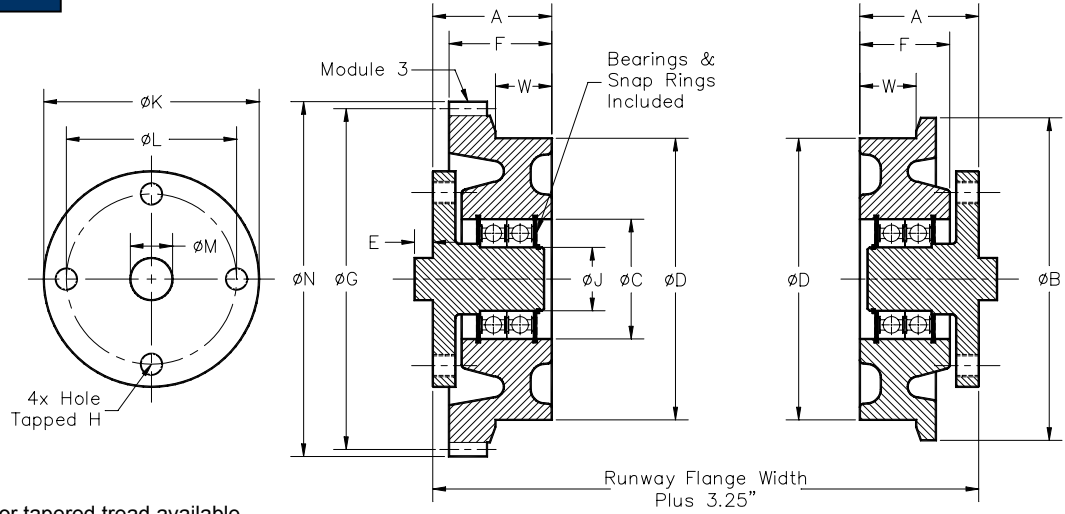

Plain or tapered tread available

Model		A	B	C	D (Tread Dia.)	E	F	G (Pitch Dia.)	H	J (Axle Dia.)	K	L	M	N	W	No of Teeth	Gear Module	Max Wheel Load
SF130	mm	64	160	62	130	6	58	156	1/2-13NC	30	102	82	30	162	26	52	3	1497 kg
	in	2.52	6.30	2.44	5.12	0.24	2.28	6.14	1/2-13NC	1.18	4.02	3.23	1.18	6.38	1.02	52	3	3300 lbs
SF200	mm	76	229	85	200	13	73	247	5/8-11NC	45	153	121	30	252	40	82	3	2983 kg
	in	2.99	9.02	3.35	7.87	0.51	2.87	9.72	5/8-11NC	1.77	6.02	4.76	1.18	9.92	1.57	82	3	6578 lbs
SF315	mm	-	346	120	315	-	110	387	-	55	-	-	-	393	55	129	3	6338 kg
	in	-	13.62	4.72	12.40	-	4.33	15.24	-	2.17	-	-	-	15.47	2.17	129	3	13975 lbs

## Axle Modules for Single Flange Wheels

Model		A	B (Axle Dia.)	C	D	E	F	G	H (Tapped)
SFA30	mm	67	30	6	30	82	102	14	1/2-13NC
	in	2.64	1.18	0.24	1.18	3.23	4.02	0.55	1/2-13NC
SFA45	mm	90	45	13	30	121	153	16	5/8-11NC
	in	3.54	1.77	0.51	1.18	4.76	6.02	0.63	5/8-11NC

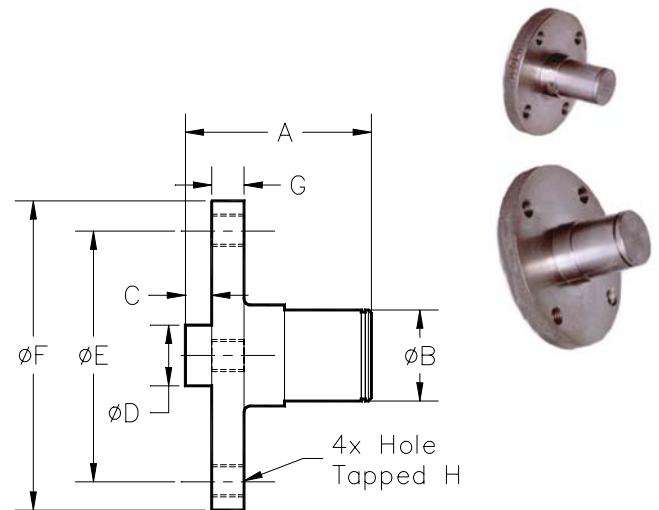

## Pinions

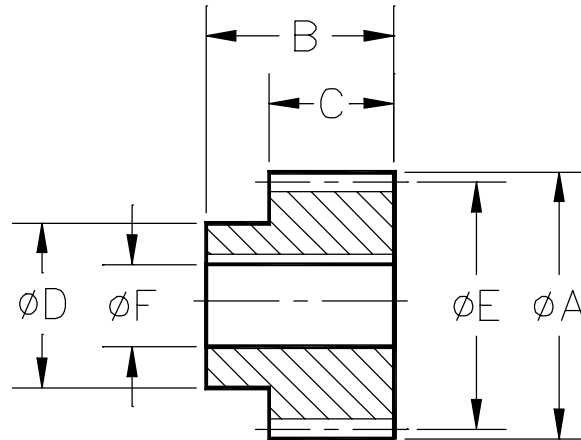

Model		A	B	C	D	E (Pitch Dia.)	F Available Bores	No. Of Teeth	Module	Suits Wheel Models
M318	mm	60	57	38	42	54	--	18	3	SF130, SF200, SF315, DF120, DF200, DF320
	in	2.36	2.24	1.50	1.65	2.13	0.750, 0.875, 1.000			
M325	mm	81	57	38	50	75	--	25	3	SF130, SF200, SF315, DF120, DF200, DF320
	in	3.19	2.24	1.50	1.97	2.95	0.750, 0.875, 1.000			
M418	mm	80	100	57	60	72	--	18	4	DF500
	in	3.15	3.94	2.24	2.36	2.83	1.000, 1.250			
M425	mm	108	100	57	83	100	--	25	4	DF500
	in	4.25	3.94	2.24	3.27	3.94	1.000, 1.250			

## Crane Wheel Setup

### Double Flange Wheels

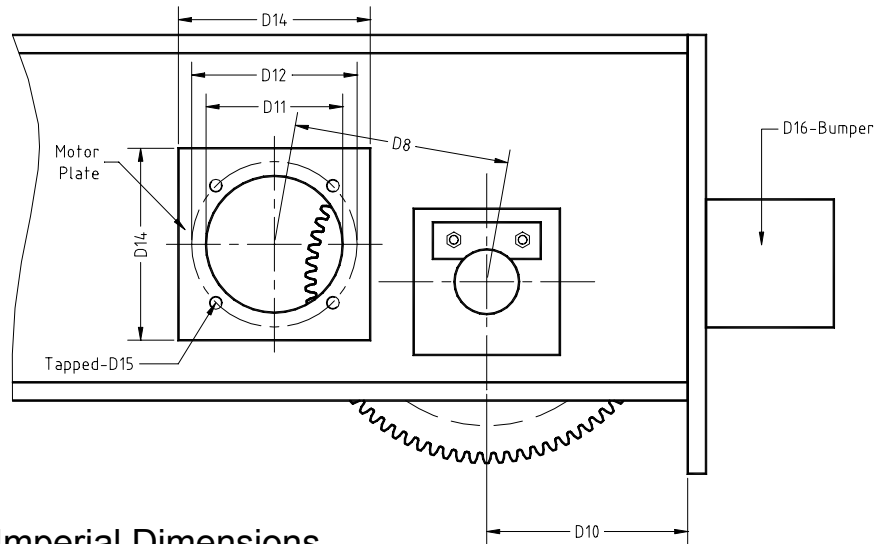
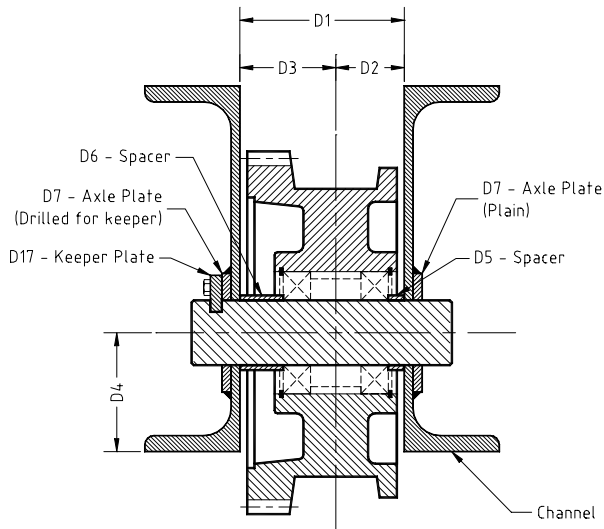

### Double Flange Wheel Assembly - Imperial Dimensions

PART NO.	TREAD DIAM.	D1	D2	D3	D4	PART NO. D5	PART NO. D6	PART NO. D7	18T PINION D8	25T PINION D8	D10	PART NO. D16	PART NO. D17
DF120	4.72	4.00	2.31	1.69	1.63	SP1-120	SP2-120	AP02	4.134	4.547	6.00	BP01	KP01
DF200	7.87	4.50	1.86	2.65	3.25	SP1-200	SP2-200	AP03	5.906	6.319	6.50	BP01	KP01
DF320	12.60	6.00	3.68	2.33	5.25	SP1-320	SP2-320	AP04	-	9.094	9.50	BP01	KP01
DF500	19.69	8.00	4.79	3.21	7.50	SP1-500	SP2-500	AP05	-	9.626	15.00	BP01	KP01

### Double Flange Wheel Assembly - Metric Dimensions

PART NO.	TREAD DIAM.	D1	D2	D3	D4	PART NO. D5	PART NO. D6	PART NO. D7	18T PINION D8	25T PINION D8	D10	PART NO. D16	PART NO. D17
DF120	120	102	59	43	41	SP1-120	SP2-120	AP02	105	115	152	BP01	KP01
DF200	200	114	47	67	83	SP1-200	SP2-200	AP03	150	161	165	BP01	KP01
DF320	320	152	93	59	133	SP1-320	SP2-320	AP04	-	231	241	BP01	KP01
DF500	500	203	122	82	191	SP1-500	SP2-500	AP05	-	245	381	BP01	KP01

### Motor Plate - Imperial Dimensions

PART NO.	D11	D12	D14	D15
MP140	3.74	4.53	5.50	5/16-18UNC
MP160	4.33	5.12	6.50	3/8-16UNC
MP200	5.12	6.50	8.00	3/8-16UNC

### Motor Plate - Metric Dimensions

PART NO.	D11	D12	D14	D15
MP140	95	115	140	5/16-18UNC
MP160	110	130	165	3/8-16UNC
MP200	130	165	203	3/8-16UNC

## Crane Wheel Setup

### Single Flange Wheels

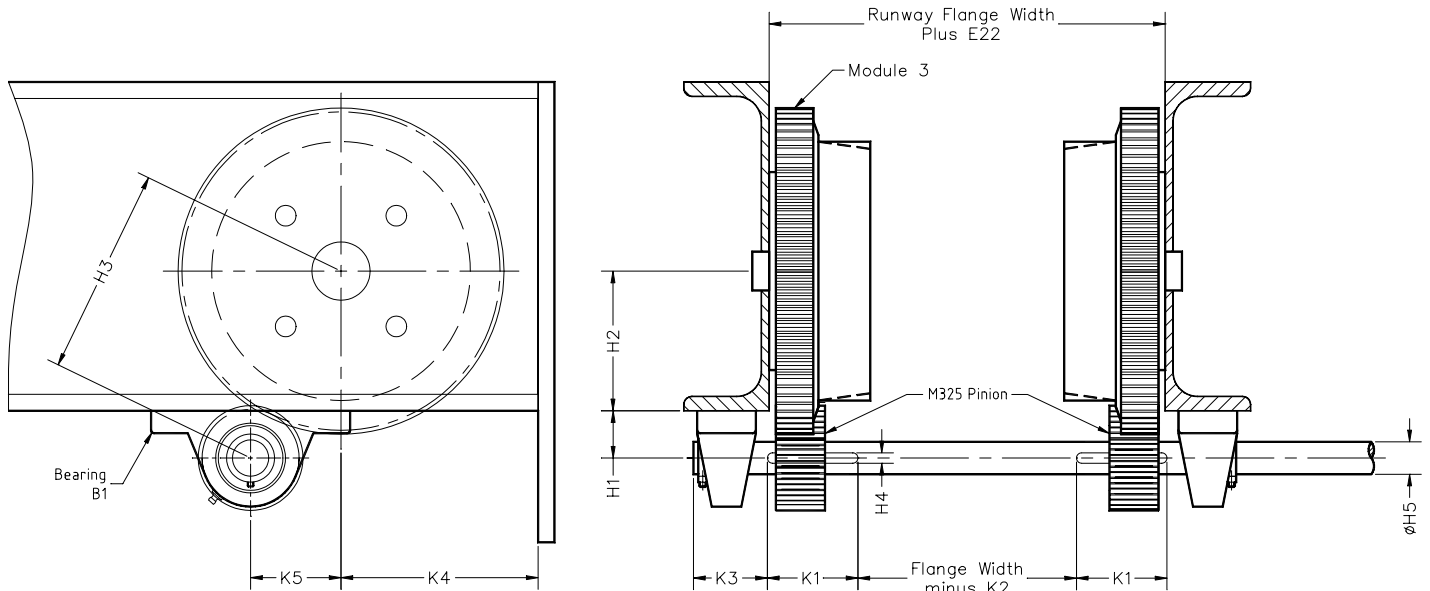

### Single Flange Wheel Assembly - Imperial Dimensions

WHEEL TYPE	TREAD DIA.	E22	H1	H2	WITH M325 PINION H3	H4	H5	K1	K2	K3	K4	K5	PART NO. B1
SF130	5.12	3.25	1.44	3.00	4.55	0.25	1.00	2.75	2.15	2.75	6.0	0.99	UCP205-1
SF200	7.87	3.25	1.44	4.25	6.32	0.25	1.00	2.75	2.15	2.75	6.0	2.75	UCP205-1
SF315	12.40	3.25	1.44	7.50	9.09	0.25	1.00	2.75	2.15	2.75	9.0	1.68	UCP205-1

### Single Flange Wheel Assembly - Metric Dimensions

WHEEL TYPE	TREAD DIA.	E22	H1	H2	WITH M325 PINION H3	H4	H5	K1	K2	K3	K4	K5	PART NO. B1
SF130	130	83	36.5	76.2	115.5	8	25	70	55	70	152	25.2	UCP205-25
SF200	200	83	36.5	108.0	160.5	8	25	70	55	70	152	69.9	UCP205-25
SF315	315	83	36.5	190.5	231.0	8	25	70	55	70	229	42.7	UCP205-25